

# TER3M0 Robot Motor Controls

## Pictorial Diagram

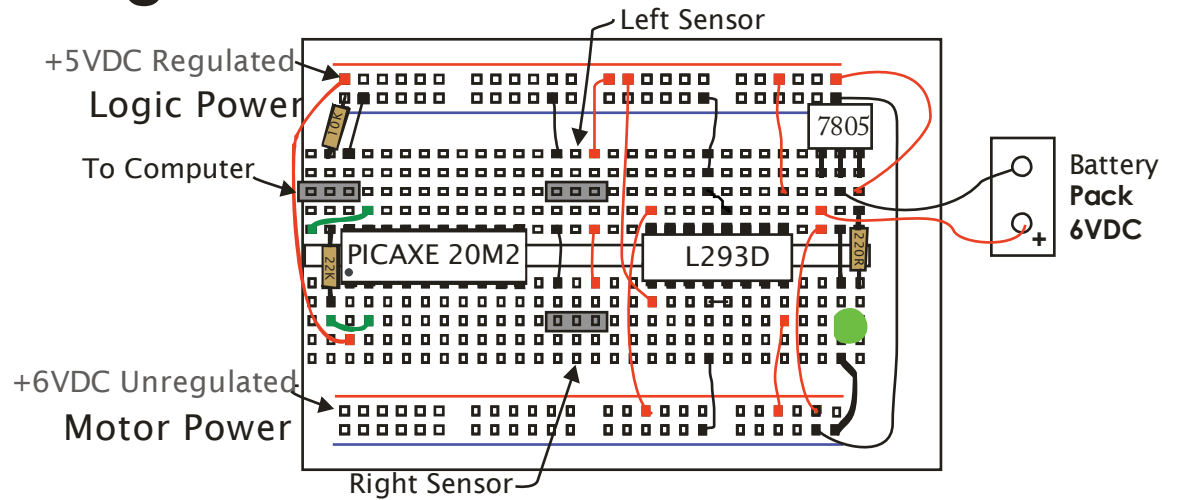

## Pinout Diagram

### PICAXE-20M2

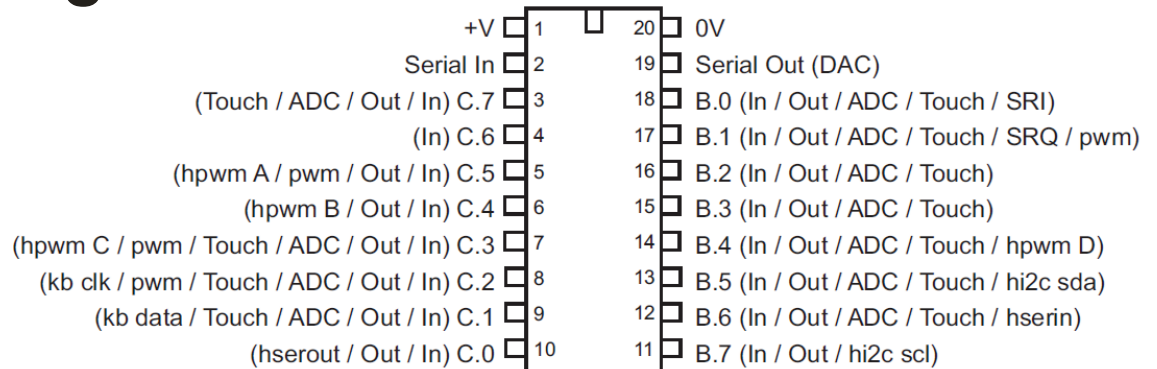

## Logic Diagram

### PICAXE 20M2 Microcontroller

Vcc Pin 1  
GND Pin 20

### L293D Dual H-Bridge

Vcc Pins 8, 16  
GND Pins 4,5,12,13

